

SPECIFICATION FOR APPROVAL

REF. :

PROD. NAME	Shielded SMD Power Inductor	ABC'S DWG NO.	SS0906□□□□L□-□□□		
		REV.	20130109-B	PAGE	1

I . Configuration and dimensions :

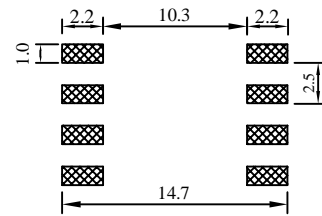
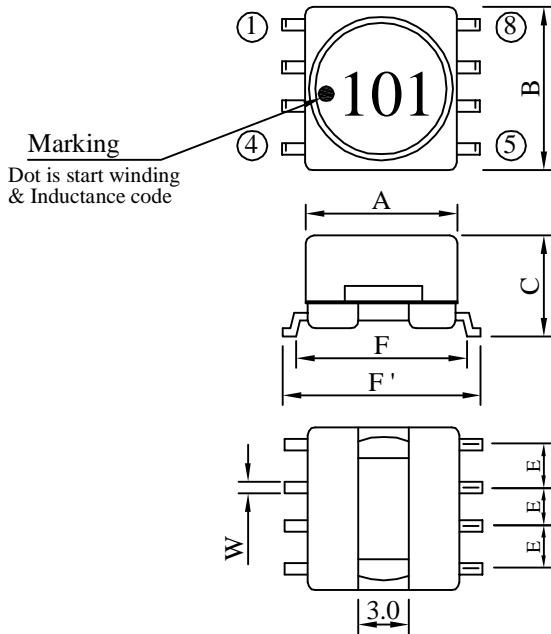

(PCB Pattern)

Unit : m/m

A	B	C	E	F	F'	W
9.50 ±0.3	10.50 max.	6.00±0.3	2.50±0.3	11.0±.5	12.70±0.8	0.60 typ.

II . Description :

- a . Ferrite drum core construction.
- b . Magnetically epoxy.
- c . Enamelled copper wire : F class
- d . Product weight : 1.60 g (ref.)
- e . Moisture sensitivity Level 1
- f . Products comply with RoHS' requirements
- g . Halogen free available

III . General specification :

- a . Storage temp. : -40°C ----+125°C
- b . Operating temp. : -40°C ----+125°C
(Temp. rise included)
- c . Resistance to solder heat : 245°C .10 secs.

Peak Temp : 245°C max.
Max. Peak Temp - 5°C : 30sec max.
Max time above 217°C : 60sec~150sec max.

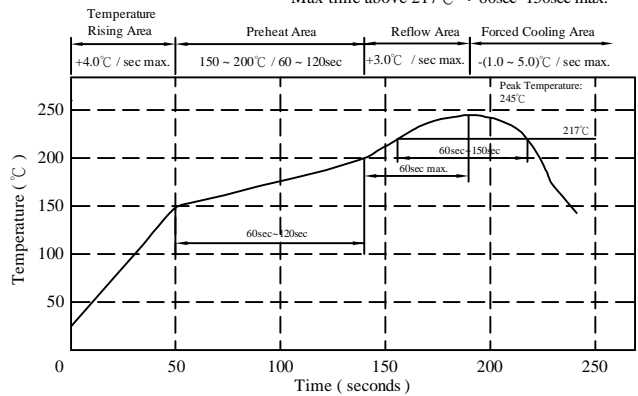

AR-001C

SPECIFICATION FOR APPROVAL

REF. :

PROD. NAME	Shielded SMD Power Inductor	ABC'S DWG NO.	SS0906□□□□L□-□□□		
		REV.	20130109-B	PAGE	2

IV . Electrical characteristics :

DWG No.	Inductance (μH)	Q ref.	Test Freq. (Hz)		SRF (MHz) nom.	RDC (Ω) max	IDC (A) max
			L	Q			
SS09062R7ML□-□□□	2.70±20%	23	1K	7.960M	85.0	0.032	3.20
SS09063R5ML□-□□□	3.50±20%	23	1K	7.960M	80.0	0.036	2.90
SS09064R7ML□-□□□	4.70±20%	23	1K	7.960M	70.0	0.040	2.70
SS09065R6ML□-□□□	5.60±20%	23	1K	7.960M	57.0	0.046	2.50
SS09066R8ML□-□□□	6.80±20%	23	1K	7.960M	38.0	0.050	2.30
SS09068R2ML□-□□□	8.20±20%	23	1K	7.960M	30.0	0.055	2.10
SS0906100ML□-□□□	10.00±20%	35	1K	2.520M	29.0	0.080	1.80
SS0906120ML□-□□□	12.00±20%	35	1K	2.520M	26.0	0.085	1.70
SS0906150ML□-□□□	15.00±20%	35	1K	2.520M	29.0	0.100	1.60
SS0906180ML□-□□□	18.00±20%	35	1K	2.520M	22.0	0.110	1.50
SS0906220ML□-□□□	22.00±20%	35	1K	2.520M	19.0	0.130	1.40
SS0906270ML□-□□□	27.00±20%	35	1K	2.520M	17.0	0.140	1.30
SS0906330ML□-□□□	33.00±20%	35	1K	2.520M	15.0	0.150	1.20
SS0906390ML□-□□□	39.00±20%	35	1K	2.520M	14.0	0.160	1.10
SS0906470ML□-□□□	47.00±20%	35	1K	2.520M	12.0	0.180	1.00
SS0906560ML□-□□□	56.00±20%	35	1K	2.520M	12.0	0.300	0.93
SS0906680ML□-□□□	68.00±20%	40	1K	2.520M	9.0	0.350	0.85
SS0906820ML□-□□□	82.00±20%	40	1K	2.520M	8.0	0.370	0.78
SS0906101YL□-□□□	100.00±15%	40	1K	0.796M	7.5	0.420	0.70
SS0906121YL□-□□□	120.00±15%	40	1K	0.796M	7.0	0.480	0.65
SS0906151YL□-□□□	150.00±15%	40	1K	0.796M	6.0	0.550	0.60
SS0906181YL□-□□□	180.00±15%	40	1K	0.796M	5.5	0.820	0.52
SS0906221YL□-□□□	220.00±15%	40	1K	0.796M	5.0	1.000	0.48
SS0906271YL□-□□□	270.00±15%	40	1K	0.796M	5.0	1.100	0.44
SS0906331YL□-□□□	330.00±15%	40	1K	0.796M	4.5	1.300	0.40
SS0906391YL□-□□□	390.00±15%	40	1K	0.796M	4.2	1.400	0.38
SS0906471YL□-□□□	470.00±15%	40	1K	0.796M	4.0	1.600	0.35
SS0906561YL□-□□□	560.00±15%	60	1K	0.796M	3.2	2.700	0.28
SS0906681YL□-□□□	680.00±15%	60	1K	0.796M	2.7	3.200	0.25
SS0906821YL□-□□□	820.00±15%	85	1K	0.796M	2.6	3.500	0.23
SS0906102YL□-□□□	1000.00±15%	100	1K	0.252M	2.3	4.000	0.22
SS0906122YL□-□□□	1200.00±15%	100	1K	0.252M	2.3	4.400	0.20
SS0906152YL□-□□□	1500.00±15%	100	1K	0.252M	2.0	5.200	0.18
SS0906182YL□-□□□	1800.00±15%	100	1K	0.252M	1.7	7.000	0.17
SS0906222YL□-□□□	2200.00±15%	100	1K	0.252M	1.5	8.500	0.16
SS0906272YL□-□□□	2700.00±15%	100	1K	0.252M	1.4	9.200	0.14
SS0906332YL□-□□□	3300.00±15%	100	1K	0.252M	1.3	11.000	0.12
SS0906392YL□-□□□	3900.00±15%	100	1K	0.252M	1.2	16.000	0.11
SS0906472YL□-□□□	4700.00±15%	100	1K	0.252M	1.0	19.000	0.10
SS0906562YL□-□□□	5600.00±15%	100	1K	0.252M	0.9	21.000	0.09
SS0906682YL□-□□□	6800.00±15%	100	1K	0.252M	0.9	24.000	0.09
SS0906822YL□-□□□	8200.00±15%	100	1K	0.252M	0.8	31.000	0.08
SS0906103YL□-□□□	10000.00±15%	100	1K	79.60K	0.7	38.000	0.07

- 1). □ : Packaging information : □ Code
- 2). "- □□□ " : Reference code
- 3). Electrical specifications at 25°C
- 4). IDC base on Temp. rise 40°C max. & ΔL/L0A=10% max.

AR-001C

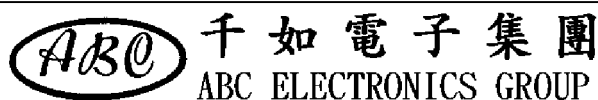

SPECIFICATION FOR APPROVAL

REF. :

PROD. NAME	Shielded SMD Power Inductor	ABC'S DWG NO.	SS0906□□□□L□-□□□		
		REV.	20130109-B	PAGE	3

V . Curve :

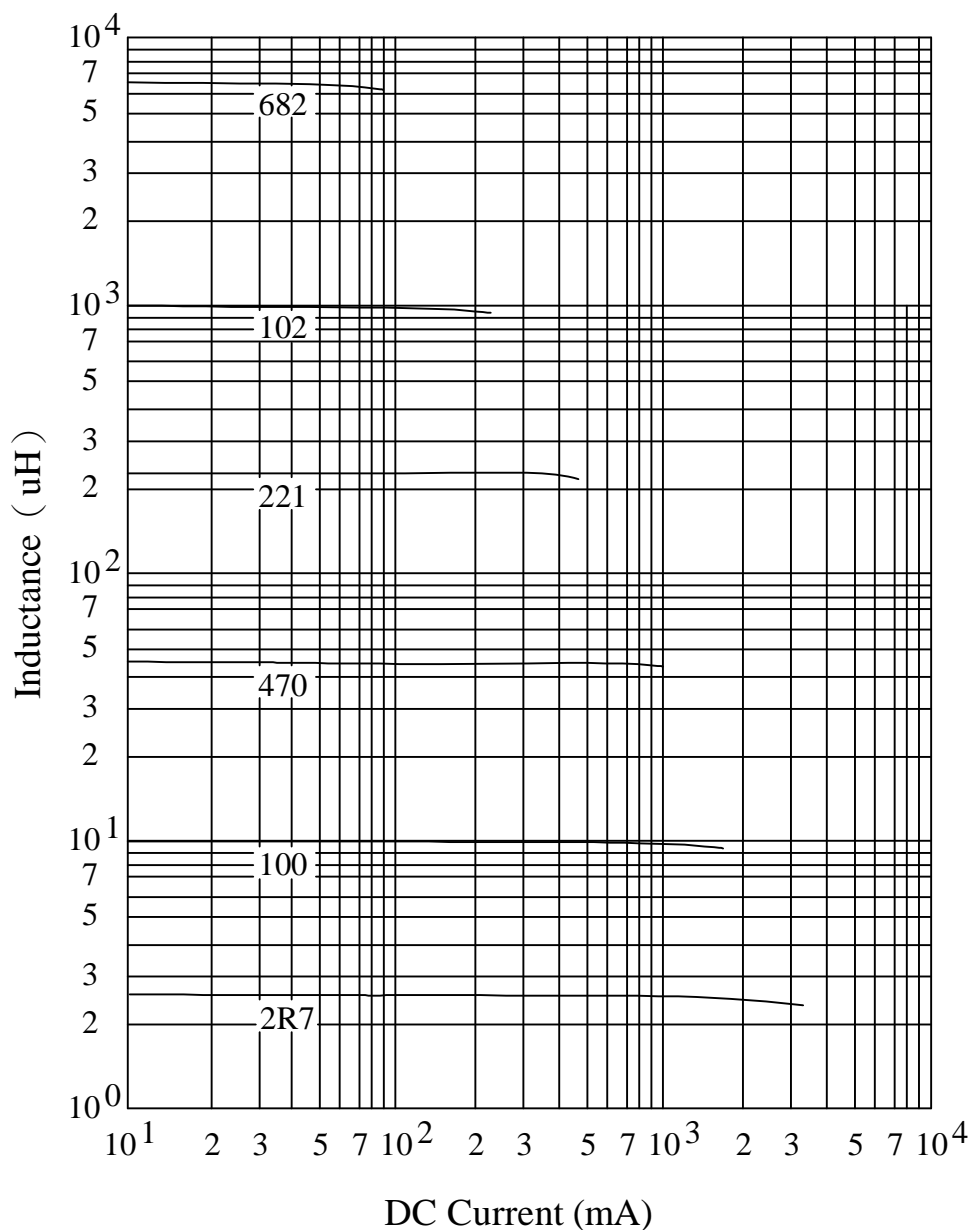

AR-001C

SPECIFICATION FOR APPROVAL

REF. :

PROD. NAME	Shielded SMD Power Inductor	ABC'S DWG NO.	SS0906□□□□L□-□□□		
		REV.	20130109-B	PAGE	4

VI . Packaging information :

(1) Configuration

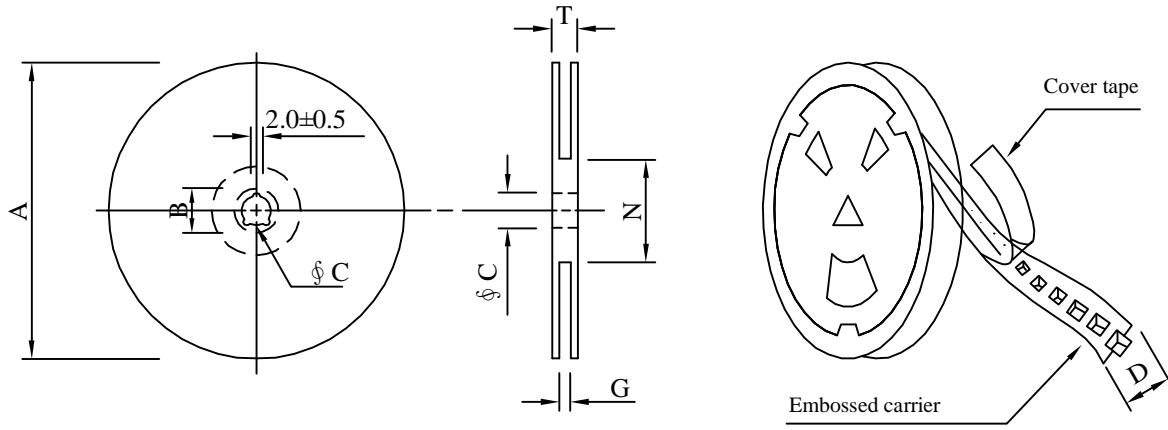

※Carrier tape width : D

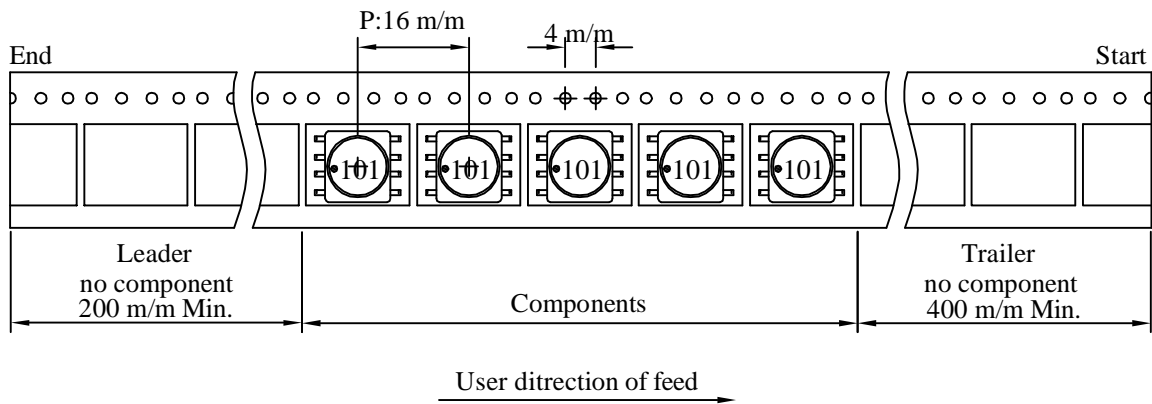

(2) Dimensions

Unit:m/m

Style	A	B	C	D	G	N	T
13 - 24	330	21±0.8	13	24	26 ⁺⁰	60 ⁻⁰	30.4

(3) Q'TY & G.W. Per package

Code	Inner : Reel			Outer : Carton		
	Q'TY (pcs)	G.W. (gw)	Style	Q'TY (pcs)	G.W. (Kg)	Size (cm)
B	600	2000	13 - 24	2,400	10.2	38 x 37 x 22

AR-001C

SPECIFICATION FOR APPROVAL

REF. :

PROD. NAME	Shielded SMD Power Inductor	ABC'S DWG NO.	SS0906□□□□L□-□□□		
		REV.	20130109-B	PAGE	5

VII . Reliability test :

Item	Reference documents	Test Condition	Test Specification
1.High Temperature Exposure	MIL-STD-202 Method 108	1.Temperature: 125℃ 2.Time:96 hours.	1.No mechanical and electrical damage. 2.Inductance shall not change more than ±20%.
2.Temperature Cycling	JESD22 Method JA-104	1.Temperature: -40℃ ~ 125℃ 2.Number of cycle:96 cycle 3.Dwell time:30 minutes	1.No mechanical and electrical damage. 2.Inductance shall not change more than ±20%.
3.Biased Humidity Test	MIL-STD-202 Method 103	1.Temperature: 85±5℃ 2.Time:96 Hours 3.Humidity: 85±5% RH.	1.No mechanical and electrical damage. 2.Inductance shall not change more than ±20%.
4.Operational Life	MIL-PRF-27	1.Temperature: 125℃ 2.Time:96 hours. 3.Apply rated current.	1.No mechanical and electrical damage. 2.Inductance shall not change more than ±20%.
5.Exeternal Visual	MIL-STD-883 Method 2009	Inspect product constructions, marking and workmanship.	1.No pollution on the surface of products. 2.Clear marking. 3.No crack.
6.Physical Dimensions	JESD22 Method JB-100	Verify physical dimensions to the applicable product detail specification.	Per product specification standard
7.Resistance to solvents	MIL-STD-202 Method 215	Immerse into solvent for 3±0.5 minutes & brush 10 times for their cycles.	1.No body change in apperance. 2.No marking blurred. 3.Inductance shall not change more than ±20%.
8.Vibration Test	MIL-STD-202 Method 204	1.Frequency and Amplitued : 10-2000-10 Hz, 1.5 mm. 2.Direction:X, Y, Z 3.Test duration:2 hours for each direction, 6 hours in total.	1.No mechanical and electrical damage. 2.Inductance shall not change more than ±20%.
9.Resistance To Soldering Heat Test	MIL-STD-202 Method 210	1.Highest temperature : 245±5℃ 2.Time (temp. ≥ 217℃) : 60~150 Second. 3.IR reflow times : 3 times.	1.No mechanical and electrical damage. 2.Inductance shall not change more than ±20%.
10.Rated current	MIL-STD-202 Method 330	Apply rated current for 5 second.	1.No mechanical and electrical damage. 2.Inductance shall not change more than ±20%.
11.Temperature rise	MIL-PRF-27	Apply rated current for 10 minutes.	1.No mechanical and electrical damage. 2.Inductance shall not change more than ±20%.
12.Over load	MIL-PRF-27	Apply twice as rated current for 5 minutes. (It's not application to some special design)	1.No mechanical and electrical damage. 2.Inductance shall not change more than ±20%.
13.Solderability Test	J-STD-002	1.Baking in pre-testing : 155±5℃ / 16Hours±30 min. 2.Peak temperature : 240±5℃ 3.Time (temp. ≥ 217℃) : 60~150 second. 4.IR reflow times : 1 times.	The terminal shall be at least 95% covered with fresh solder.
14.Electrical Characteriazation	User Spec.	1.Operating temperature : -40℃~125℃ 2.Room temperature : 25℃.	1.No mechanical and electrical damage. 2.Inductance shall not change more than ±20%.
15.Withstanding Voltage Test	MIL-STD-202 Method 201	1.DV:500V 2.Time:1minutes	1.During the test no breakdown. 2.The characteristic is normal after test.
16.Drop	JESD22-B111	Packaged & Drop down from 1m.In 1 angle 1ridges & 2 surfaces orientation.	1.No case deformation or change in appearance. 2.Inductance shall not change more than ±20%.
17.Terminal Strength Test	JIS-C-6429	1.Apply push force to samples mounted on PCB. 2.Force of 1.8 kg for 60±1 seconds.	After test, inductors shall be no mechanical damage.

AR-001C