

SPECIFICATION FOR APPROVAL

REF. :

PROD. NAME	Shielded SMD Power Inductor	ABC'S DWG NO.	SS1210□□□□F□-□□□		
		REV.	20191118-F	PAGE	1

I . Configuration and dimensions :

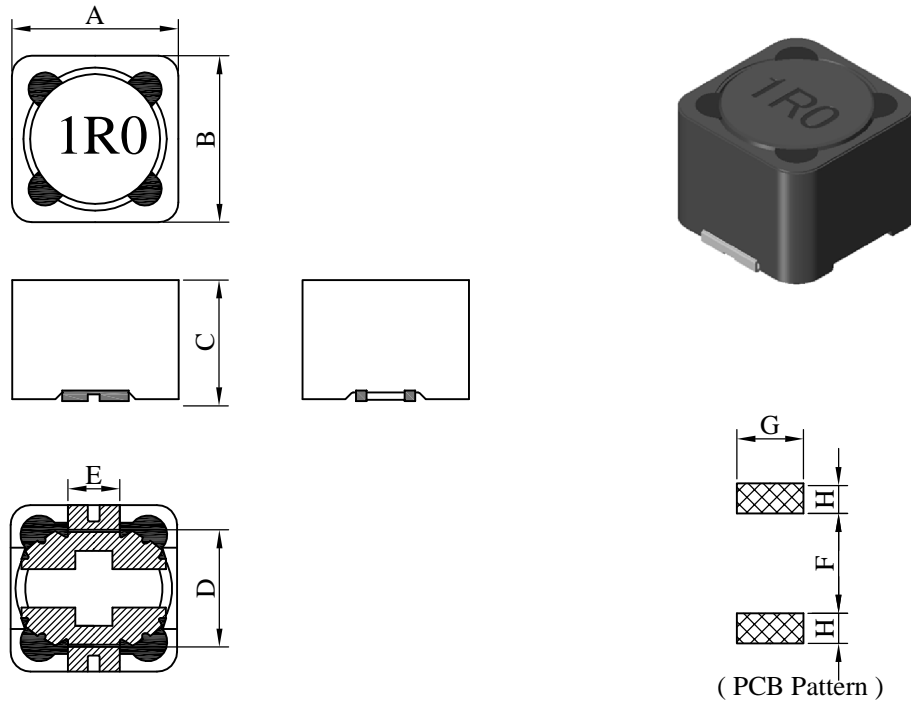

Unit : mm

A	B	C	D	E	F	G	H
12.00 ±0.5	12.00 ±0.5	10.00 max.	7.90 ref.	4.90 ref.	7.30 ref.	5.30 ref.	2.80 ref.

II . Description :

- a . Ferrite drum core construction
- b . Magnetically shielded
- c . Enamelled copper wire : F class
- d . Product weight : 4.50g (ref.)
- e . Moisture sensitivity Level 1
- f . Products comply with RoHS' requirements
- g . Halogen free

III . General specification :

- a . Storage temp. : -40°C ----+125°C
- b . Operating temp. : -40°C ----+125°C
(Temp. rise included)
- c . Resistance to solder heat : 260°C .10 secs.

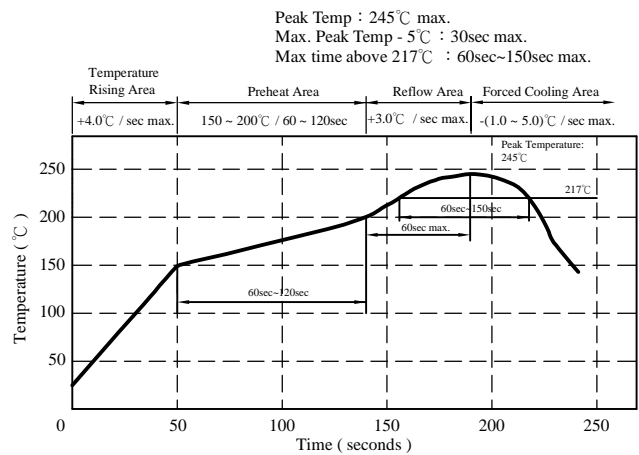

AR-001C

SPECIFICATION FOR APPROVAL

REF. :

PROD. NAME	Shielded SMD Power Inductor	ABC'S DWG NO.	SS1210□□□□F□-□□□		
		REV.	20191118-F	PAGE	2

IV . Electrical characteristics :

DWG No.	Inductance (μ H)	Q ref.	Test Freq. (MHz)	SRF (MHz) typ.	RDC (m Ω) max.	I _{rms} (A) typ.	I _{sat} (A) max.
SS12101R0YFB-□□□	1.0 \pm 30%	10	7.960	85.00	6.0	11.00	16.50
SS12101R8YFB-□□□	1.8 \pm 30%	10	7.960	56.00	7.5	10.20	13.20
SS12102R2YFB-□□□	2.2 \pm 30%	10	7.960	54.00	9.0	9.50	12.20
SS12103R3YFB-□□□	3.3 \pm 30%	15	7.960	44.00	10.0	9.00	10.50
SS12104R7YFB-□□□	4.7 \pm 30%	8	7.960	35.00	12.0	8.50	9.60
SS12105R6YFB-□□□	5.6 \pm 30%	12	7.960	28.00	13.5	8.00	8.50
SS12106R8YFB-□□□	6.8 \pm 30%	12	7.960	20.00	15.0	7.85	8.30
SS12108R2YFB-□□□	8.2 \pm 30%	11	7.960	16.00	17.0	7.25	7.55
SS1210100MFB-□□□	10.0 \pm 20%	16	2.520	12.00	18.0	6.50	6.50
SS1210120MFB-□□□	12.0 \pm 20%	14	2.520	18.00	22.0	6.30	6.10
SS1210150MFB-□□□	15.0 \pm 20%	16	2.520	10.50	32.0	5.80	5.30
SS1210180MFB-□□□	18.0 \pm 20%	13	2.520	8.00	35.0	5.50	5.10
SS1210220MFB-□□□	22.0 \pm 20%	16	2.520	8.00	38.0	5.20	4.50
SS1210270MFB-□□□	27.0 \pm 20%	16	2.520	6.50	40.0	5.00	4.20
SS1210330MFB-□□□	33.0 \pm 20%	16	2.520	6.50	52.0	4.40	3.70
SS1210390MFB-□□□	39.0 \pm 20%	16	2.520	4.50	66.0	4.20	3.50
SS1210470MFB-□□□	47.0 \pm 20%	16	2.520	4.50	72.0	3.80	3.10
SS1210560MFB-□□□	56.0 \pm 20%	8	2.520	4.00	90.0	3.40	2.90
SS1210680MFB-□□□	68.0 \pm 20%	12	2.520	3.80	102.0	3.00	2.70

AR-001C

SPECIFICATION FOR APPROVAL

REF. :

PROD. NAME	Shielded SMD Power Inductor	ABC'S DWG NO.	SS1210□□□□F□-□□□		
		REV.	20191118-F	PAGE	3

DWG No.	Inductance (μ H)	Q ref.	Test Freq. (MHz)	SRF (MHz) typ.	RDC (m Ω) max.	Irms (A) typ.	Isat (A) max.
SS1210820MFB-□□□	82.0 \pm 20%	15	2.520	3.50	112.0	2.80	2.50
SS1210101MFB-□□□	100.0 \pm 20%	16	0.796	3.00	135.0	2.50	2.20
SS1210121MFB-□□□	120.0 \pm 20%	13	0.796	2.60	170.0	2.30	1.90
SS1210151MFB-□□□	150.0 \pm 20%	12	0.796	2.20	190.0	2.20	1.80
SS1210181MFB-□□□	180.0 \pm 20%	14	0.796	1.80	250.0	1.90	1.60
SS1210221MFB-□□□	220.0 \pm 20%	15	0.796	1.80	315.0	1.70	1.50
SS1210271MFB-□□□	270.0 \pm 20%	16	0.796	1.80	410.0	1.50	1.30
SS1210331MFB-□□□	330.0 \pm 20%	14	0.796	1.80	450.0	1.40	1.20
SS1210391MFB-□□□	390.0 \pm 20%	16	0.796	1.30	600.0	1.30	1.10
SS1210471MFB-□□□	470.0 \pm 20%	12	0.796	0.85	820.0	1.20	1.00
SS1210561MFB-□□□	560.0 \pm 20%	12	0.796	0.85	900.0	1.10	0.95
SS1210681MFB-□□□	680.0 \pm 20%	11	0.796	0.85	1200.0	1.00	0.85
SS1210821MFB-□□□	820.0 \pm 20%	6	0.796	0.85	1320.0	0.85	0.75
SS1210102MFB-□□□	1000.0 \pm 20%	22	0.796	0.85	1650.0	0.75	0.70

- 1). Electrical specifications at 25°C
- 2). Inductance Test Freq. : 1kHz / 0.25V
- 3). I rms base on Temp. rise 40°C typ.
- 4). Isat base on $\Delta L/L0A=20\%$ max.

AR-001C

SPECIFICATION FOR APPROVAL

REF. :

PROD. NAME	Shielded SMD Power Inductor	ABC'S DWG NO.	SS1210□□□□F□-□□□		
		REV.	20191118-F	PAGE	4

V . Curve :

SS12104R7YF□

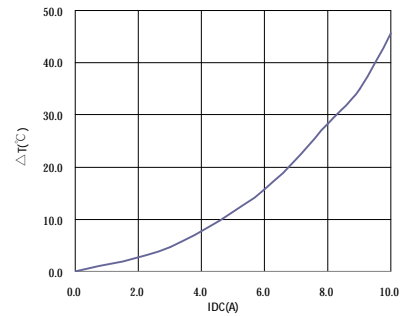
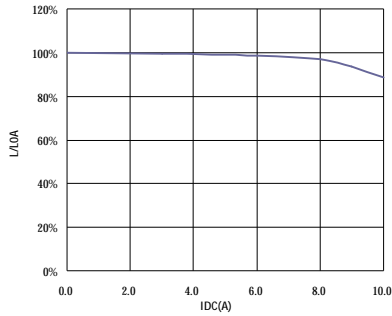

SS1210220MF□

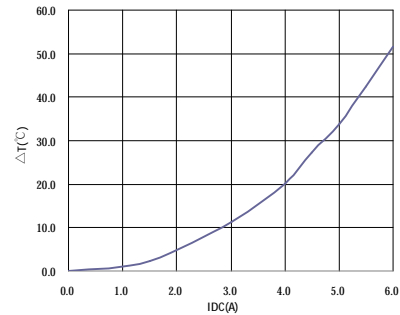
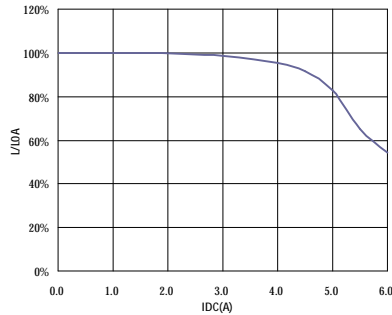

SS1210101MF□

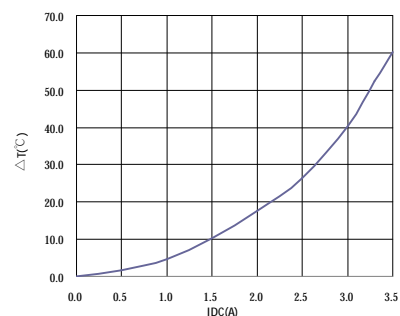
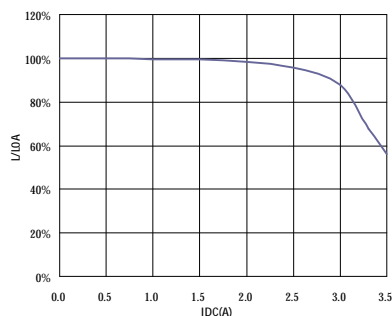

SS1210102MF□

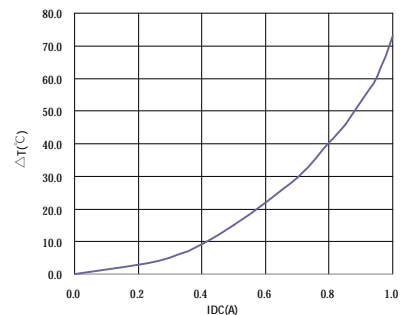
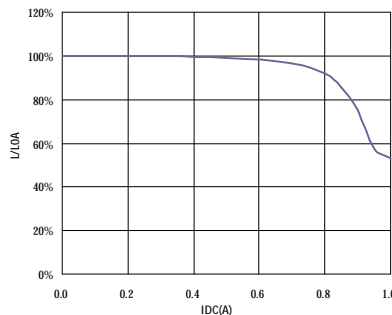

AR-001C

SPECIFICATION FOR APPROVAL

REF. :

PROD. NAME	Shielded SMD Power Inductor	ABC'S DWG NO.	SS1210□□□□F□-□□□		
		REV.	20191118-F	PAGE	5

VI . Packaging information :

(1) Configuration

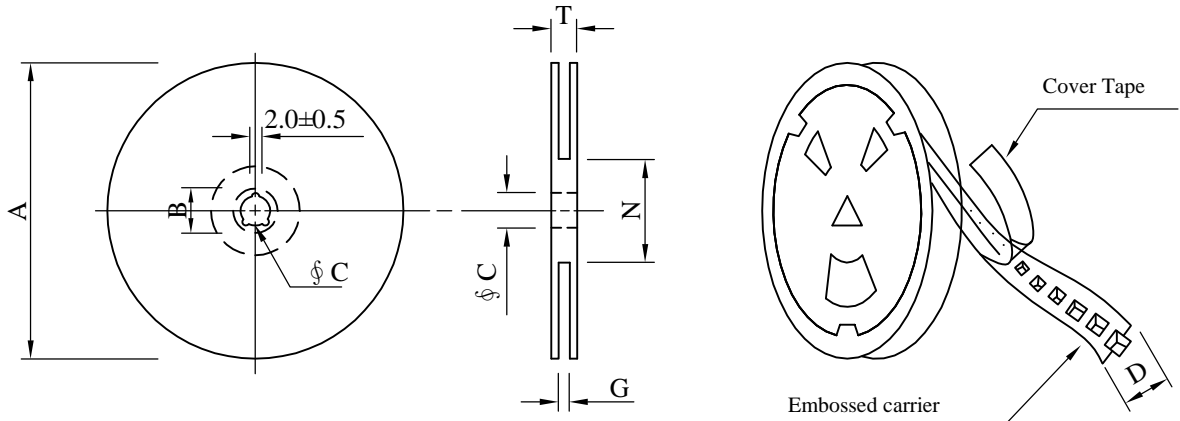

※Carrier tape width : D

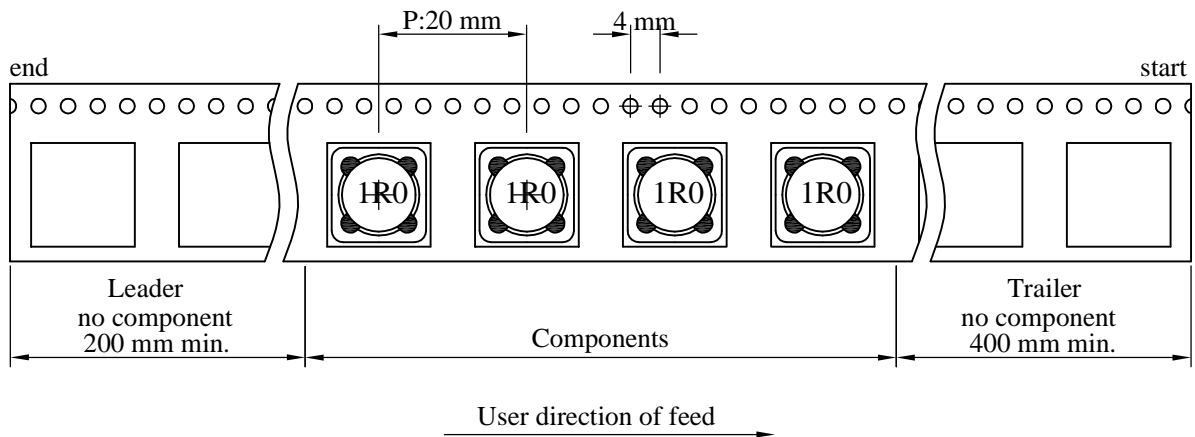

(2) Dimensions

Unit:mm

Style	A	B	C	D	G	N	T
13 - 24	330	21±0.8	13±0.5	24	26 ⁺⁰	60 ⁻⁰	30.4

(3) Q'TY & G.W. Per package

Code	Inner : Reel			Outer : Carton		
	Q'TY (pcs)	G.W. (g)	Style	Q'TY (PCS)	G.W. (kg)	Size (cm)
B	250	1710	13 - 24	1,000	8.1	38 x 37 x 22

AR-001C

SPECIFICATION FOR APPROVAL

REF. :

PROD. NAME	Shielded SMD Power Inductor	ABC'S DWG NO.	SS1210□□□□F□-□□□		
		REV.	20191118-F	PAGE	6

VII . Drawing number expression :

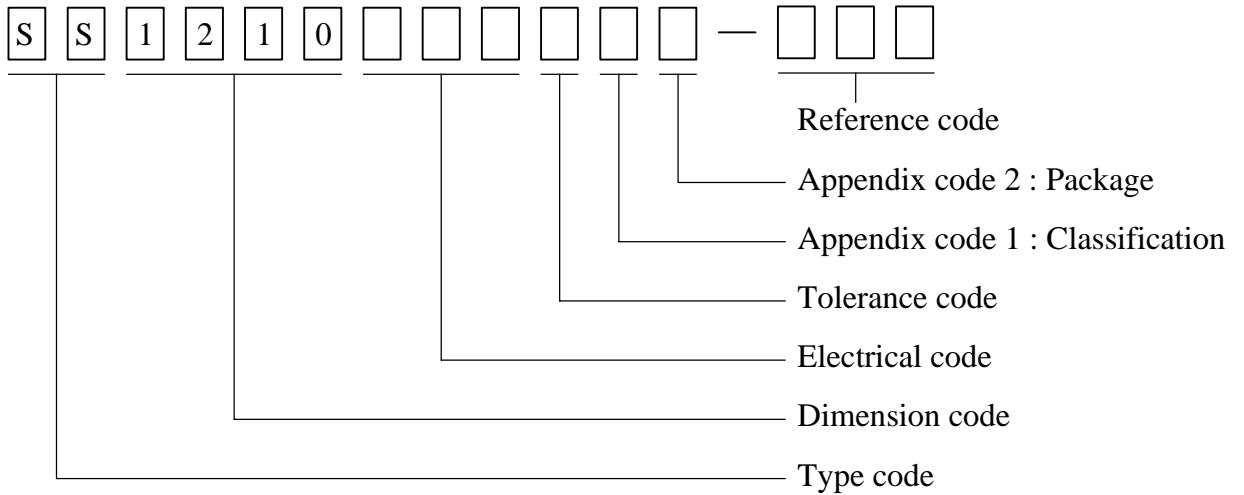

Appendix code 1 : Product Classification

Appendix code 2 : Package Information

Code	Inner package	Cover tape	Carrier tape	Bag	Package Q'TY	Remark
B	T/R (Reel package)	UCT	Antistatic	Antistatic	250 pcs	

AR-001C

SPECIFICATION FOR APPROVAL

REF. :

PROD. NAME	Shielded SMD Power Inductor	ABC'S DWG NO.	SS1210□□□□F□-□□□		
		REV.	20191118-F	PAGE	7

VIII . Reliability test :

Item	Reference documents	Test Condition	Test Specification
1.High Temperature Exposure	MIL-STD-202 Method 108	1.Temperature: 125±2℃ 2.Time:96±2 hours.	1.No mechanical or electrical damage. 2.Inductance shall not change more than ±20%.
2.Temperature Cycling	JESD22-A 104	1.Temperature: -40℃ ~ +125℃ 2.Number of cycle:100 cycles 3.Dwell time:30 minutes	1.No mechanical or electrical damage. 2.Inductance shall not change more than ±20%.
3.Biased Humidity Test	MIL-STD-202 Method 103	1.Temperature : 85±2 ℃ 2.Humidity: 85% RH. 3.Time:96±2 Hours	1.No mechanical or electrical damage. 2.Inductance shall not change more than ±20%.
4.Operational Life	JESD22-A 108	1.Temperature: 125℃ (Temp. rise included) 2.Time:96±2 hours. 3.Rated current	1.No mechanical or electrical damage. 2.Inductance shall not change more than ±20%.
5.External Visual	JESD22-B 101 & MIL-STD-883 Method 2009	Inspect product constructions, marking and workmanship.	1.No pollution on the surface of products. 2.Clear marking. 3.No crack.
6.Physical Dimensions	JESD22-B 100	Verify physical dimensions to the applicable product detail specification.	Per product specification standard
7.Resistance to solvents	MIL-STD-202 Method 215	Immerse into solvent for 3±0.5 minutes & brush 10 times for 3 cycles.	1.No body change in apperarence. 2.No marking blurred. 3.Inductance shall not change more than ±20%.
8.Vibration Test	MIL-STD-202 Method 204	1.Frequency and Amplitued : 10-2000-10 Hz, 1.5 mm. 2.Direction:X, Y, Z 3.Test duration:2 hours for each direction, 6 hours in total.	1.No mechanical or electrical damage. 2.Inductance shall not change more than ±20%.
9.Resistance To Soldering Heat Test	MIL-STD-202 Method 210 & J-STD020D.1	1.Highest temperature : 245±5℃. 2.Time (temp. ≥ 217℃) : 60~150 Seconds. 3.IR reflow times : 3 times.	1.No mechanical or electrical damage. 2.Inductance shall not change more than ±20%.
10.Saturation Current	JIS C 6436 & User SPEC.	1.Applied rated current for 5 seconds. 2.Saturation current	Inductance shall not drop more than 20% max.
11.Over load	JIS C 6436 & User SPEC.	1.Applied one and half rated current for a period of 5 minutes. 2.Rated current	No electrical or mechanical damage
12.Temperature Rise Current	JIS C 6436 & User SPEC.	1.Applied rated current for 10 minutes. 2.Temperature measure by digital surface thermometer. 3.Irms current	Surface temperature rise is less than 40℃ typ.
13.Solderability Test	J-STD-002 & JESD22-B 102	1.Baking in pre-testing : 150±5℃ / 16Hours±30 min. 2.Peak temperature : 240±5℃ 3.Time (temp. ≥ 217℃) : 60~150 seconds. 4.IR reflow times : 1 time.	More than 95% soldering coverage min on terminations.
14.Electrical Characteriazation	MIL-STD-202 Method 304 & User SPEC.	1.Operating temperature : -40℃~125℃ 2.Room temperature : 25℃.	1.No mechanical or electrical damage. 2.Inductance shall not change more than ±20%.
15.Drop	CNS-C6354 & GB/T 2423.8	1.Products shall be mounted on SPEC. PCB and dropped down from a height of 1m 2.Drop total time : 6 times (Every side of sample drop 2 times)	1. Adhesion on PCB shall be enough. 2. Product appearance shall not break. 3. No electrical damage.
16.Terminal Strength Test	IEC 60068-2-21	1.Apply push force to samples mounted on PCB. 2.Force of 1.8 kg for 60±1 seconds.	After test, inductors shall be no mechanical damage.

AR-001C