

# SPECIFICATION FOR APPROVAL

REF. :

PROD. NAME	Shielded SMD Power Inductor	ABC'S DWG NO.	SS1240□□□□L□-□□□		
		REV.	20191118-H	PAGE	1

**I . Configuration and dimensions :**

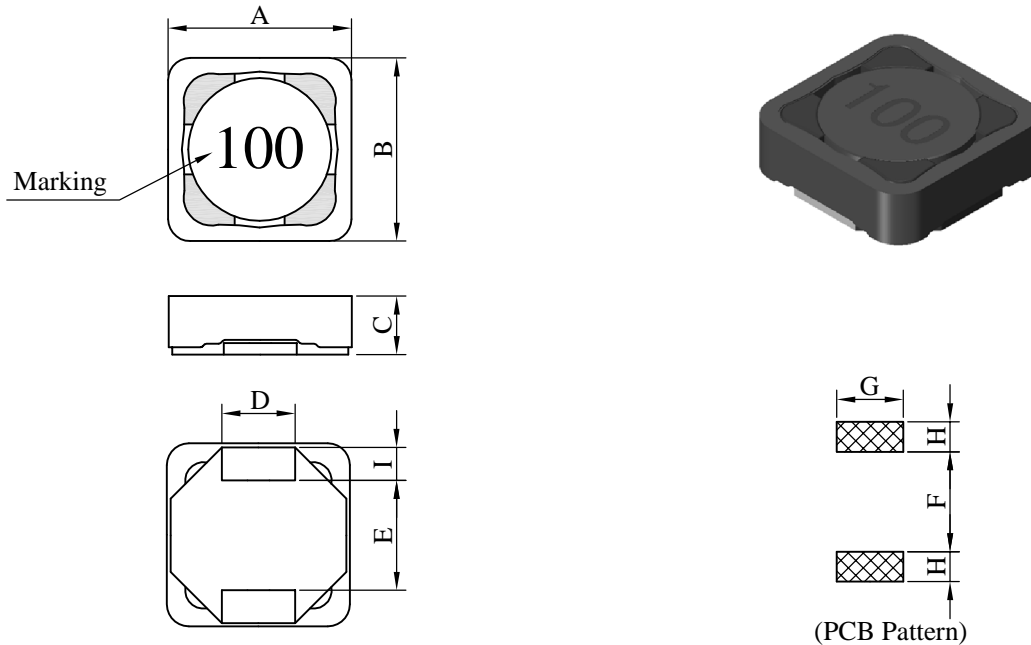

Unit : mm

A	B	C	D	E	I	F	G	H
12.50 ±0.3	12.50 ±0.3	4.00 ±0.5	5.00 ±0.3	7.00 typ.	2.50 ±0.15	6.80 ref.	5.40 ref.	2.90 ref.

**II . Description :**

- a . Ferrite drum core construction
- b . Magnetically shielded
- c . Enamelled copper wire : F class
- d . Product weight : 2.35g ( ref. )
- e . Moisture sensitivity Level 1
- f . Products comply with RoHS' requirements
- g . Halogen free

**III . General specification :**

- a . Storage temp. : -40°C ----+125°C
- b . Operating temp. : -40°C ----+125°C  
(Temp. rise included)
- c . Resistance to solder heat : 260°C .10 secs.

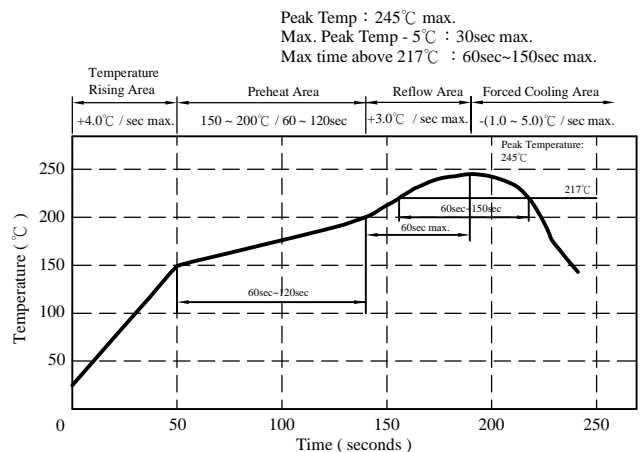

AR-001C

# SPECIFICATION FOR APPROVAL

REF. :

PROD. NAME	Shielded SMD Power Inductor	ABC'S DWG NO.	SS1240□□□□L□-□□□		
		REV.	20191118-H	PAGE	2

## IV . Electrical characteristics :

DWG. No.	Inductance ( $\mu$ H )	Q ref.	Test Freq. ( MHz )	SRF ( MHz ) typ.	RDC ( m $\Omega$ ) max.	I <sub>rms</sub> ( A ) typ.	I <sub>sat</sub> ( A ) typ.
SS12401R0YL□-□□□	1.0±30%	10	7.96	85.0	7.0	9.30	9.20
SS12401R5YL□-□□□	1.5±30%	16	7.96	80.0	9.5	9.20	9.00
SS12402R4YL□-□□□	2.4±30%	10	7.96	54.0	11.5	8.00	7.80
SS12403R3YL□-□□□	3.3±30%	14	7.96	43.0	15.0	6.80	6.50
SS12404R7ML□-□□□	4.7±20%	16	7.96	33.0	18.0	6.00	5.60
SS12405R6ML□-□□□	5.6±20%	14	7.96	35.0	20.0	5.40	5.10
SS12406R8ML□-□□□	6.8±20%	14	7.96	34.0	23.0	5.20	4.70
SS12408R2ML□-□□□	8.2±20%	10	7.96	32.0	27.0	4.50	4.30
SS1240100ML□-□□□	10.0±20%	17	2.52	27.0	32.0	4.00	4.00
SS1240120ML□-□□□	12.0±20%	16	2.52	25.0	38.0	3.80	3.60
SS1240150ML□-□□□	15.0±20%	16	2.52	22.0	47.0	3.50	3.20
SS1240180ML□-□□□	18.0±20%	14	2.52	20.0	55.0	3.20	3.00
SS1240220ML□-□□□	22.0±20%	18	2.52	16.0	67.5	3.00	2.60
SS1240270ML□-□□□	27.0±20%	16	2.52	15.5	85.0	2.55	2.35
SS1240330ML□-□□□	33.0±20%	19	2.52	15.0	97.0	2.30	2.10
SS1240390ML□-□□□	39.0±20%	14	2.52	14.0	120.0	2.15	2.00
SS1240470ML□-□□□	47.0±20%	19	2.52	13.0	135.0	2.00	1.80
SS1240560ML□-□□□	56.0±20%	16	2.52	12.0	170.0	1.80	1.65
SS1240680ML□-□□□	68.0±20%	19	2.52	11.0	200.0	1.50	1.50
SS1240820ML□-□□□	82.0±20%	16	2.52	10.0	250.0	1.35	1.35
SS1240101ML□-□□□	100.0±20%	14	0.796	8.0	300.0	1.25	1.20
SS1240121KL□-□□□	120.0±10%	12	0.796	7.8	370.0	1.20	1.15
SS1240151KL□-□□□	150.0±10%	12	0.796	7.5	440.0	1.10	1.05
SS1240181KL□-□□□	180.0±10%	12	0.796	7.0	550.0	0.98	0.95
SS1240221KL□-□□□	220.0±10%	12	0.796	6.6	600.0	0.92	0.90
SS1240271KL□-□□□	270.0±10%	10	0.796	6.0	780.0	0.80	0.80
SS1240331KL□-□□□	330.0±10%	12	0.796	5.5	950.0	0.75	0.75
SS1240391KL□-□□□	390.0±10%	12	0.796	5.0	1150.0	0.70	0.65
SS1240471KL□-□□□	470.0±10%	12	0.796	4.5	1350.0	0.62	0.60
SS1240561KL□-□□□	560.0±10%	12	0.796	4.0	1500.0	0.55	0.52
SS1240681KL□-□□□	680.0±10%	14	0.796	3.8	2000.0	0.50	0.48
SS1240821KL□-□□□	820.0±10%	10	0.796	3.5	2400.0	0.45	0.42
SS1240102KL□-□□□	1000.0±10%	16	0.252	2.8	3000.0	0.42	0.40

- 1). Electrical specifications at 25°C
- 2). Inductance Test Freq. : 100kHz / 0.1V
- 3). I<sub>rms</sub> base on Temp. rise 40°C typ.
- 4). I<sub>sat</sub> base on  $\Delta$ L/L0A=25% typ.

AR-001C

# SPECIFICATION FOR APPROVAL

REF. :

PROD. NAME	Shielded SMD Power Inductor	ABC'S DWG NO.	SS1240□□□□L□-□□□		
		REV.	20191118-H	PAGE	3

V . Curve :

SS1240100ML□

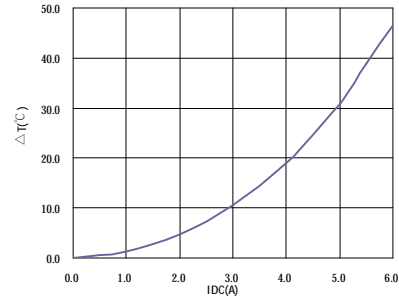
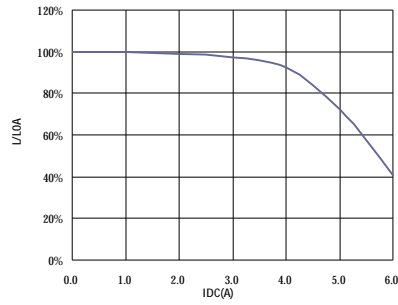

SS1240470ML□

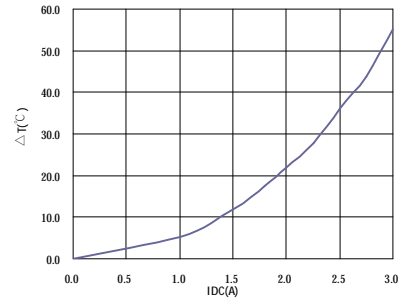
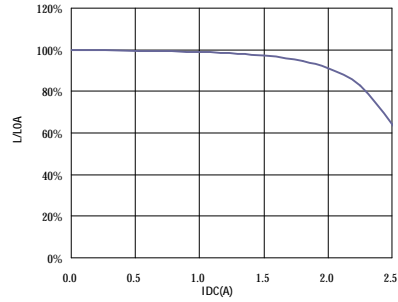

SS1240221KL□

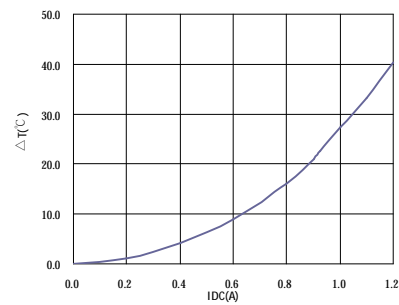
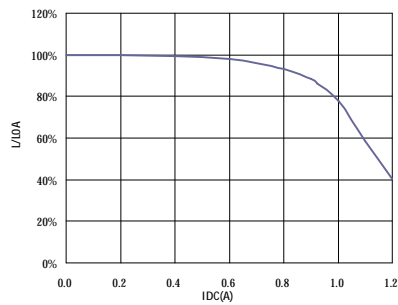

SS1240102KL□

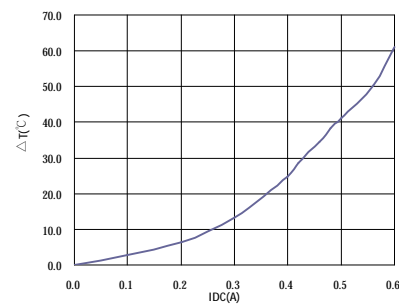
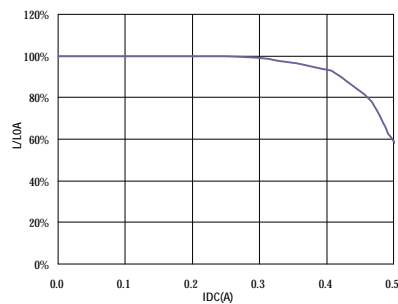

AR-001C

# SPECIFICATION FOR APPROVAL

REF. :

<b>PROD. NAME</b>	Shielded SMD Power Inductor	<b>ABC'S DWG NO.</b>	SS1240□□□□L□-□□□		
		<b>REV.</b>	20191118-H	<b>PAGE</b>	4

## VI . Packaging information :

### ( 1 ) Configuration

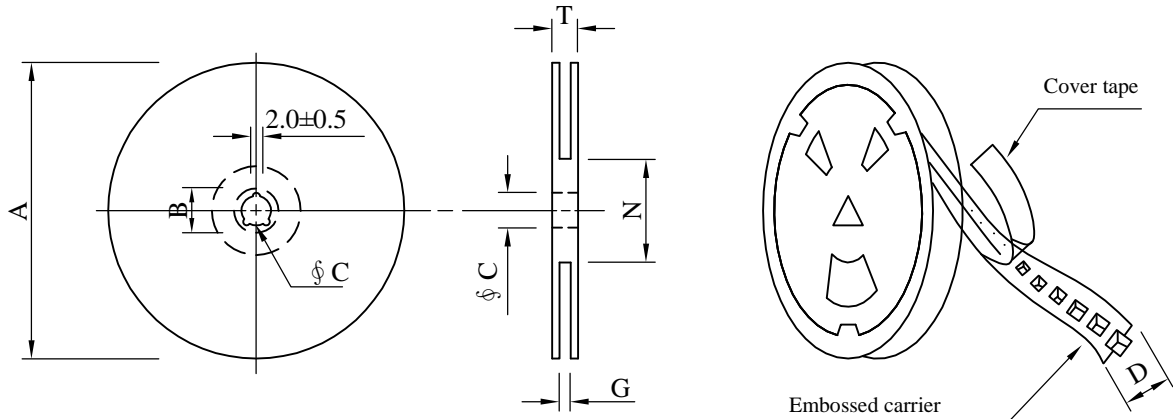

※Carrier tape width : D

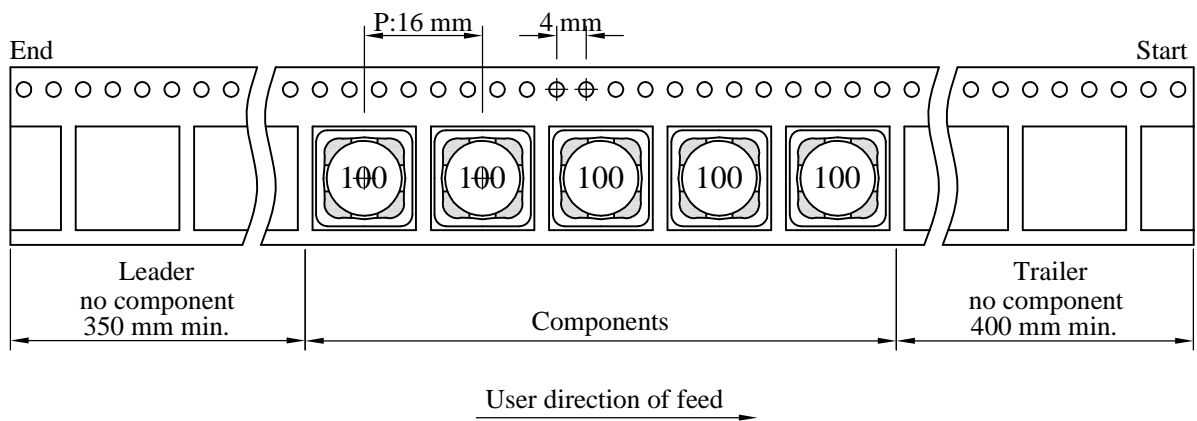

### ( 2 ) Dimensions

Unit:mm

Style	A	B	C	D	G	N	T
13 - 24	330	21±0.8	13±0.5	24	26 <sup>+0</sup>	60 <sup>-0</sup>	30.4

### ( 3 ) Q'TY & G.W. Per package

Code	Inner : Reel			Outer : Carton		
	Q'TY (pcs)	G.W. (g)	Style	Q'TY (pcs)	G.W. (kg)	Size (cm)
B	800	2280	13 - 24	3,200	10.4	38 x 37 x 22
C	500	1590	13 - 24	2,000	7.7	38 x 37 x 22

AR-001C

# SPECIFICATION FOR APPROVAL

REF. :

PROD. NAME	Shielded SMD Power Inductor	ABC'S DWG NO.	SS1240□□□□L□-□□□		
		REV.	20191118-H	PAGE	5

VII . Drawing number expression :

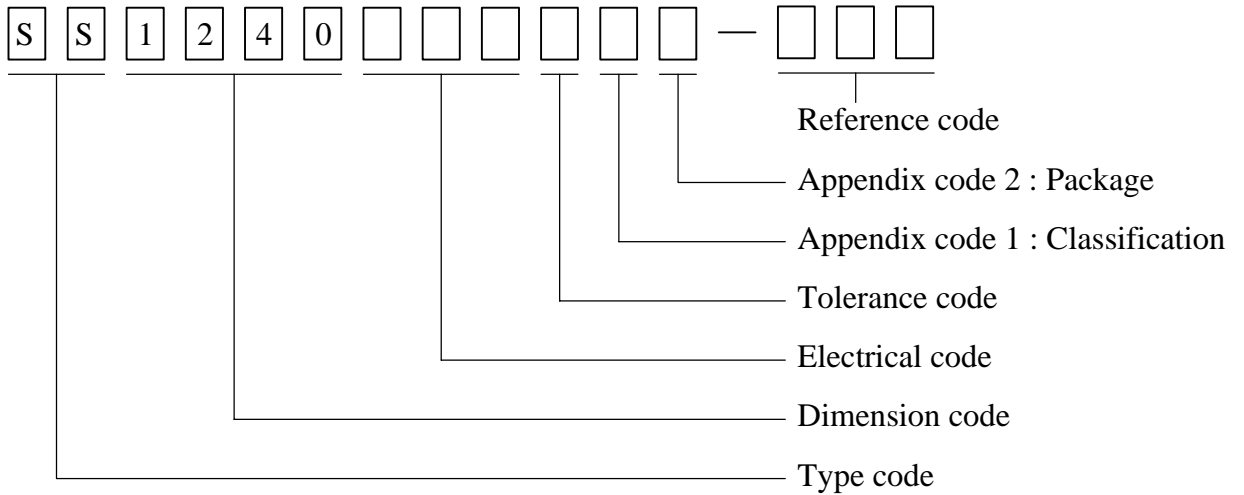

Appendix code 1 : Product Classification

Appendix code 2 : Package Information

Code	Inner package	Cover tape	Carrier tape	Bag	Package Q'TY	Remark
B	T/R (Reel package)	UCT	Antistatic	Antistatic	800 pcs	
C	T/R (Reel package)	UCT	Antistatic	Antistatic	500 pcs	

# SPECIFICATION FOR APPROVAL

REF. :

PROD. NAME	Shielded SMD Power Inductor	ABC'S DWG NO.	SS1240□□□□L□-□□□		
		REV.	20191118-H	PAGE	6

## VIII . Reliability test :

Item	Reference documents	Test Condition	Test Specification
1.High Temperature Exposure	MIL-STD-202 Method 108	1.Temperature: 125±2°C 2.Time:96±2 hours.	1.No mechanical or electrical damage. 2.Inductance shall not change more than ±20%.
2.Temperature Cycling	JESD22-A 104	1.Temperature: -40°C ~ +125°C 2.Number of cycle:100 cycle 3.Dwell time:30 minutes	1.No mechanical or electrical damage. 2.Inductance shall not change more than ±20%.
3.Biased Humidity Test	MIL-STD-202 Method 103	1.Temperature : 85±2 °C 2.Humidity: 85% RH. 3.Time:96±2 Hours	1.No mechanical or electrical damage. 2.Inductance shall not change more than ±20%.
4.Operational Life	JESD22-A 108	1.Temperature: 125°C (Temp. rise included) 2.Time:96±2 hours. 3.Rated current	1.No mechanical or electrical damage. 2.Inductance shall not change more than ±20%.
5.External Visual	JESD22-B 101 & MIL-STD-883 Method 2009	Inspect product constructions, marking and workmanship.	1.No pollution on the surface of products. 2.Clear marking. 3.No crack.
6.Physical Dimensions	JESD22-B 100	Verify physical dimensions to the applicable product detail specification.	Per product specification standard
7.Resistance to solvents	MIL-STD-202 Method 215	Immerse into solvent for 3±0.5 minutes & brush 10 times for 3 cycles.	1.No body change in appearance. 2.No marking blurred. 3.Inductance shall not change more than ±20%.
8.Vibration Test	MIL-STD-202 Method 204	1.Frequency and Amplitued : 10-2000-10 Hz, 1.5 mm. 2.Direction:X, Y, Z 3.Test duration:2 hours for each direction, 6 hours in total.	1.No mechanical or electrical damage. 2.Inductance shall not change more than ±20%.
9.Resistance To Soldering Heat Test	MIL-STD-202 Method 210 & J-STD020D.1	1.Highest temperature : 245±5°C. 2.Time ( temp. ≥ 217°C ) : 60~150 Seconds. 3.IR reflow times : 3 times.	1.No mechanical or electrical damage. 2.Inductance shall not change more than ±20%.
10.Saturation Current	JIS C 6436 & User SPEC.	1.Applied rated current for 5 seconds. 2.Saturation current	Inductance shall not drop more than 25% typ.
11.Over load	JIS C 6436 & User SPEC.	1.Applied one and half rated current for a period of 5 minutes. 2.Rated current	No electrical or mechanical damage
12.Temperature Rise Current	JIS C 6436 & User SPEC.	1.Applied rated current for 10 minutes. 2.Temperature measure by digital surface thermometer. 3.Irms current	Surface temperature rise is less than 40°C typ.
13.Solderability Test	J-STD-002 & JESD22-B 102	1.Baking in pre-testing : 150±5°C / 16Hours±30 min. 2.Peak temperature : 240±5°C 3.Time ( temp. ≥ 217°C ) : 60~150 seconds. 4.IR reflow times : 1 time.	More than 95% soldering coverage min on terminations.
14.Electrical Characteriazation	MIL-STD-202 Method 304 & User SPEC.	1.Operating temperature : -40°C~125°C 2.Room temperature : 25°C .	1.No mechanical or electrical damage. 2.Inductance shall not change more than ±20%.
15.Drop	CNS-C6354 & GB/T 2423.8	1.Products shall be mounted on SPEC. PCB and dropped down from a height of 1m 2.Drop total time : 6 times (Every side of sample drop 2 times)	1. Adhesion on PCB shall be enough. 2. Product appearance shall not break. 3. No electrical damage.
16.Terminal Strength Test	IEC 60068-2-21	1.Apply push force to samples mounted on PCB. 2.Force of 1.8 kg for 60±1 seconds.	After test, inductors shall be no mechanical damage.

AR-001C